

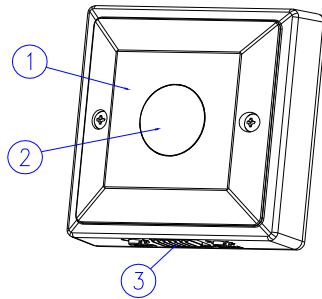

## PMWS WALL SENSOR



- ① Main Body
- ② Lens
- ③ Slide Switch

### INTRODUCTION

The PMWS 110 degrees Surface Mount PIR Wall Switch is a fully automatic indoor controller capable of controlling up to 2000W incandescent or 600W fluorescent lighting. It uses a passive infrared sensor which reacts to changes in temperature emitted by the motion of persons or objects passing through its detecting area. When you enter the room, it turns on automatically the light to which it is connected and the light remains lit as long as the wall switch senses any activity in the detection area. It however will automatically turn off the light after the preset turn-off time has expired. During the day, the built-in photocell sensor saves electricity by deactivating the light.

The PMWS is a very handy device, which offers you safety, security, convenience and energy saving. It is also easy to install and is suitable for the following places:  
living room, family room, stairways, entrance hall etc.

With this wall switch installed, you remove the problem of searching in a dark hallway or staircase for a light switch, thus avoiding danger for the elderly, infirm and children at night or in dark areas.

**Note :** Read this entire manual before you start to install the system.

### SAFETY PRECAUTIONS

- Be sure to switch off power source before installing.
- Make sure that the power wiring comes from circuit with an external miniature circuit breaker not higher than 16A for the short circuit protection or a suitable fuse.

- This unit cannot be installed on the ceiling. (FIGURE 1)

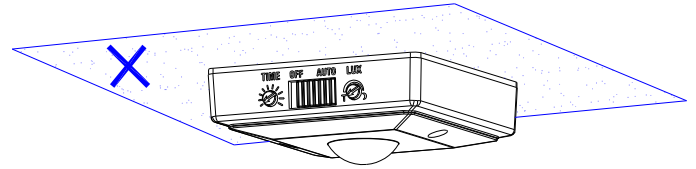

FIGURE 1

### IMPORTANT

Some local building codes may require installation of this product by a qualified electrician.

Check your local codes as they apply to your situation. If the house wiring is of aluminum, consult with an electrician about proper wiring methods.

Before proceeding with the installation, TURN OFF THE POWER TO THE LIGHTING CIRCUIT AT THE CIRCUIT BREAKER OR FUSE BOX TO AVOID ELECTRICAL SHOCK.

### CHOOSING A MOUNTING LOCATION

- For the best results, fix your sensor on a solid surface, 1.2~1.5m above the ground.
- Avoid aiming the motion sensor at pools, heating vents, air conditioners or objects which may change temperature rapidly.
- Do not allow sunlight to fall directly on the front of unit.
- Try to avoid pointing the unit where the motion of pets may be detected.
- Prior to mounting, remember to position the motion sensor so that a moving object cuts "across" its beams, not directly towards them." (FIGURE 2)

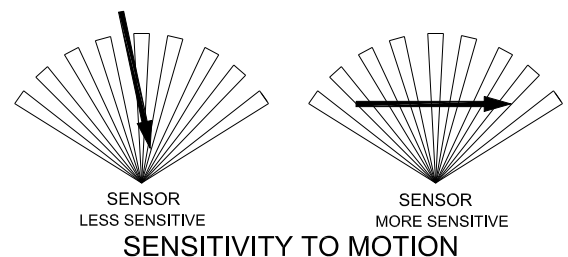

FIGURE 2

## INSTALLATION

The unit has a sensing angle of approx. 110° and can detect up to 12 meters at the mounting height of 1.5 meter or 6 meters at the mounting height of 1.2 meters. (FIGURE 3)

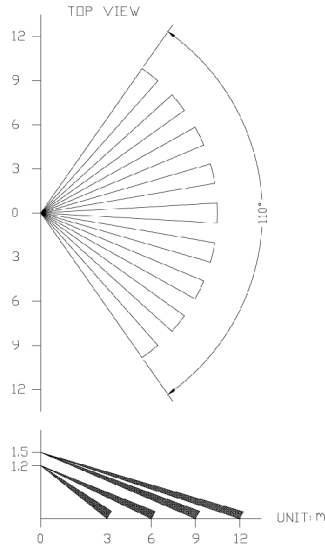

FIGURE 3

Install an external wall switch adjacent to the power source (FIGURE 4). This helps you isolate the light with ease. See OPERATION for further information.

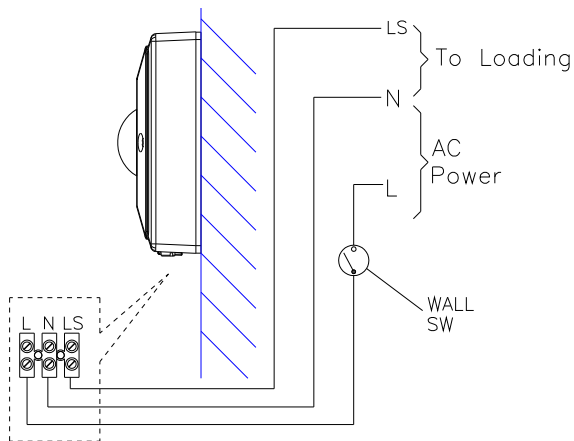

FIGURE 4

## WIRING INSTRUCTION

- (1) Switch off the power source or external wall switch.
- (2) Strip approximately 6-8mm of the insulating part of the wires from the power cord.
- (3) Connect the BROWN wire (Live wire) of power cord to the terminal block "L" mark.

Connect the BLUE wire (Neutral wire) of power cord and lamp to the terminal block "N" mark.

Connect the BROWN wire of lamp wire to the terminal block "LS" mark. (FIGURE 5)

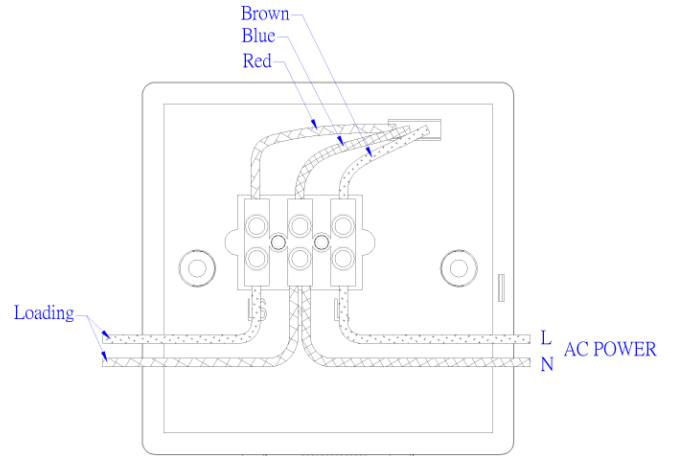

FIGURE 5

- (4) Fit the main body to the wall box and secure it with two fixing screws provided. (FIGURE 6)

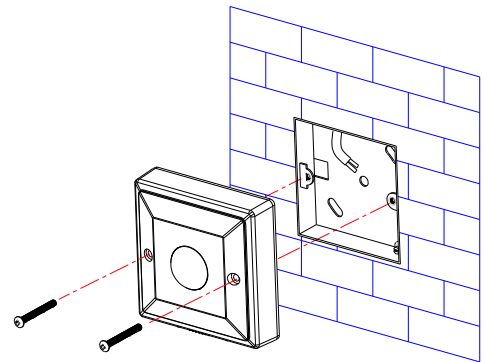

FIGURE 6

## SETTING THE LIGHTING SYSTEM

### (1) TEST MODE

- Turn the Lux control and the Time control counter-clockwise to the edge-the TEST position (FIGURE 7)

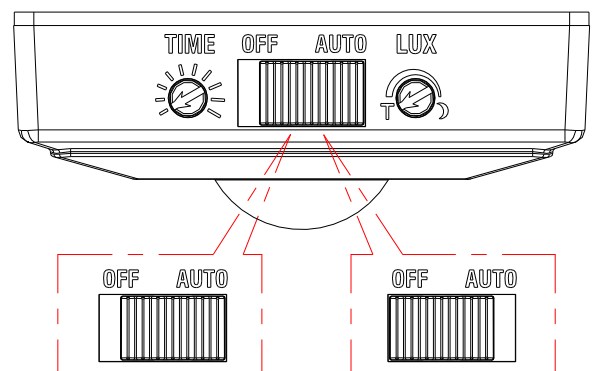

FIGURE 7

- Turn the external wall switch on, the light will turn on immediately and wait for about 1 minute to warm up the unit. After warming-up time has expired and the light goes off, you may make a walk test and the light will turn on. This confirms that the wiring was done properly and that the light is working.
- Walk through the coverage area. The light will turn on for about 3 seconds when motion is detected and turn off shortly after motion stops. Wait for the light to turn off before moving again to test the sensor.

## (2) SETTINGS

### ■ TIME ADJUSTMENT

The TIME adjustment controls how long the light will stay on after motion has been detected.

Adjust the TIME Control Knob clockwise to increase the turn-off time (40 minutes maximum) or counter-clockwise to decrease the turn-off time (3 seconds minimum). (FIGURE 8)

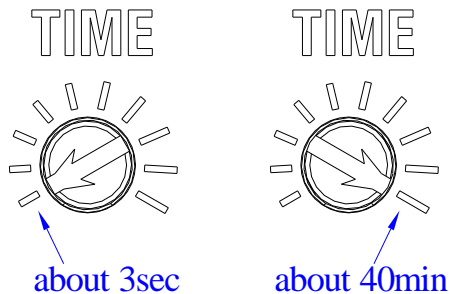

FIGURE 8

### ■ LUX ADJUSTMENT

The LUX adjustment determines at what light level the light will start operating when you set the sensor to the AUTO mode.

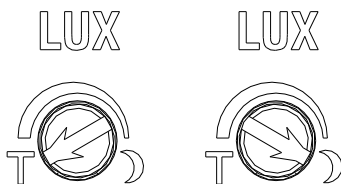

FIGURE 9

Provisionally turn the LUX Control Knob to the edge clockwise at the moon (dusk) position. (FIGURE 9) In this provisional setting mode, the Motion Sensor remains inactive during daylight. At dusk when you find it is the LUX level you desired for operation, simply set the LUX control knob to the position that you tried satisfactorily.

## OPERATION

### ■ Automatic Operation

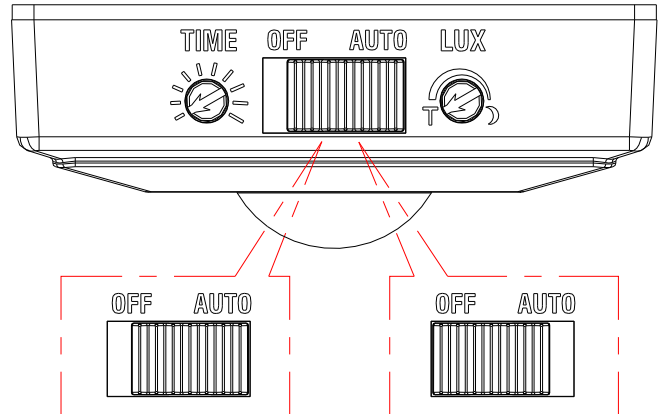

FIGURE 10

There is a slide switch located on base of the PMWS. Slide the switch to AUTO position. (FIGURE 10) When the sensor detects motion, the light automatically turns on. The built-in photocell turns the sensor off and on according to the light level selected by the LUX adjustment.

### ■ Manual Off

Sliding the switch to OFF position will turn off the connected light. (FIGURE 10) By using this OFF switch to turn off the light without using the external wall switch, the sensor won't enter 1 minute warm-up period when switching back to the AUTO mode.

## TROUBLESHOOTING

### Light does not turn on

- Confirm that you have made a correct "wiring connection".
- Make sure that the lamps have not blown..

### Light remains on

- Make sure the wiring connection is correct.
- Check if the TIME setting is correct.

### Others

- The specification of protective shield shall consult to local service agent.

SPECIFICATIONS	
Power Requirement	AC 220 ~ 240V / 50Hz
Lighting Load	Max. 2,000W Incandescent or Max. 600W Fluorescent
Detection Angle	Up to 110° at 25°C at 1.5m Height
Detection Distance	Up to 12m at 25°C at 1.5m Height
Mounting Height	Recommended 1.2 ~ 1.5m (3.9 ~ 4.9 Ft) Wall Mount
Wall Switch Control	Auto/Off
Time Adjustment	Approx. 3 seconds to 40 minutes
Lux Adjustment	Approx. 5 ~ 1000 Lux & test mode
Warm Up Time	About 1 min
Protection Class	Class II
Protection Degree	IP44
Safety	CE, GS

**Specifications are subject to change without notice.**

A501110412R01

**Warning:**

Do not dispose of electrical appliances as unsorted municipal waste, use separate collection facilities.

Contact your local government for information regarding the collection systems available.

If electrical appliances are disposed of in landfills or dumps, hazardous substances can leak into the groundwater and get into the food chain, damaging your health and well-being.

E-Matic Energy Management Solutions,  
4 Arkwright Court, Fylde Industrial Estate,  
Blackpool, Lancashire, FY4 5DR.  
Tel: 01253 791888, Fax: 01253 791887,  
Web site: [www.challenger.co.uk](http://www.challenger.co.uk),  
Email: [sales.challenger@adivision.co.uk](mailto:sales.challenger@adivision.co.uk)

